

# BEP

LEADING ELECTRICAL DESIGN

## TS1

### Ultrasonic Tank Sender

Installation and Operating Instructions



*For TS1 Firmware v3.8*

# Table of Contents

|    |                                  |    |
|----|----------------------------------|----|
| 1. | FEATURES.....                    | 3  |
| 2. | SPECIFICATIONS .....             | 3  |
| 3. | DIMENSIONS.....                  | 4  |
| 4. | MOUNTING AND INSTALLATION.....   | 5  |
| 5. | WIRING .....                     | 9  |
| 6. | PROGRAMMING AND SETUP.....       | 10 |
| 7. | PROBLEM SOLVING .....            | 10 |
| 8. | FREQUENTLY ASKED QUESTIONS ..... | 11 |

## **Important TS1 Installation Issues**

1. The sender must not be mounted closer than 150mm from the centre of the sender to sides of the tank, baffles or other intrusions.
2. Only use on tanks greater than 200mm in depth.
3. Sender must be mounted parallel to the surface of the liquid.
4. Do not install on flexible tanks that may bulge/distort as fluid levels change.
5. Check unit is calibrated to suit tank shape, depth and fluid type.
6. Make sure that sender protrusion is NOT in contact with any object including sealants when mounted.
7. Use gasket and fittings as provided.
8. Mount above deepest point of the tank.

# 1. Features

- 12V and 24V operation
- Extremely low profile only 20mm high once mounted
- Operating distance of 0mm to 2000mm maximum
- Programmable tank dimensions via windows application
- Linear and non linear tank calibration at 5 levels
- Supports metal and plastic tanks
- Supports tanks wall thickness up to 6mm (or larger if spacer is used and top limit adjusted)
- Industry standard SAE-5 stud mounting pattern with gasket seal and washers.
- Supports analogue gauge types 10-180, 300-10, 240-33
- Supports Digital meter that require 0-5 volt inputs
- Operating temperature range of 4°c to 65°c

# 2. Specifications

## Electrical

- 10V<sub>MIN</sub> to 32V<sub>MAX</sub> DC.
- Ignition protected to ISO 8846
- Fire Resistance tested to ABYC, US Coast guard and ISO10088
- Output types: Analogue 10-180, 300-10, 240-33 ohm gauges and 0-5volt

## Environmental

Resistant to Petrol, Diesel, Water, and Chemical Toilet.

## Maximum Tank depths

- Operating distance of 0mm to 1100mm for Petrol tanks
- Operating distance of 0mm to 2000mm for Water tanks
- Operating distance of 0mm to 2000mm for Diesel tanks
- Operating distance of 0mm to 1500mm at 55°c

*Note: Liquids that may have a sound absorbing surface will limit tank depth or in the worst case provide no return signal eg. foam bubbles or porous sludge.*

*Permanent liquid surfaces that are more than 3 degree's off level will have a tank depth de-rating effect.*

*Liquids that have higher viscosities than water (e.g. oil) may not propagate liquid ripples that create a strong return signal. This will also have a tank depth de-rating effect.*

*Don't use on tanks shallower than 200mm in depth as angular reflections will reduce accuracy.*

### 3. Dimensions

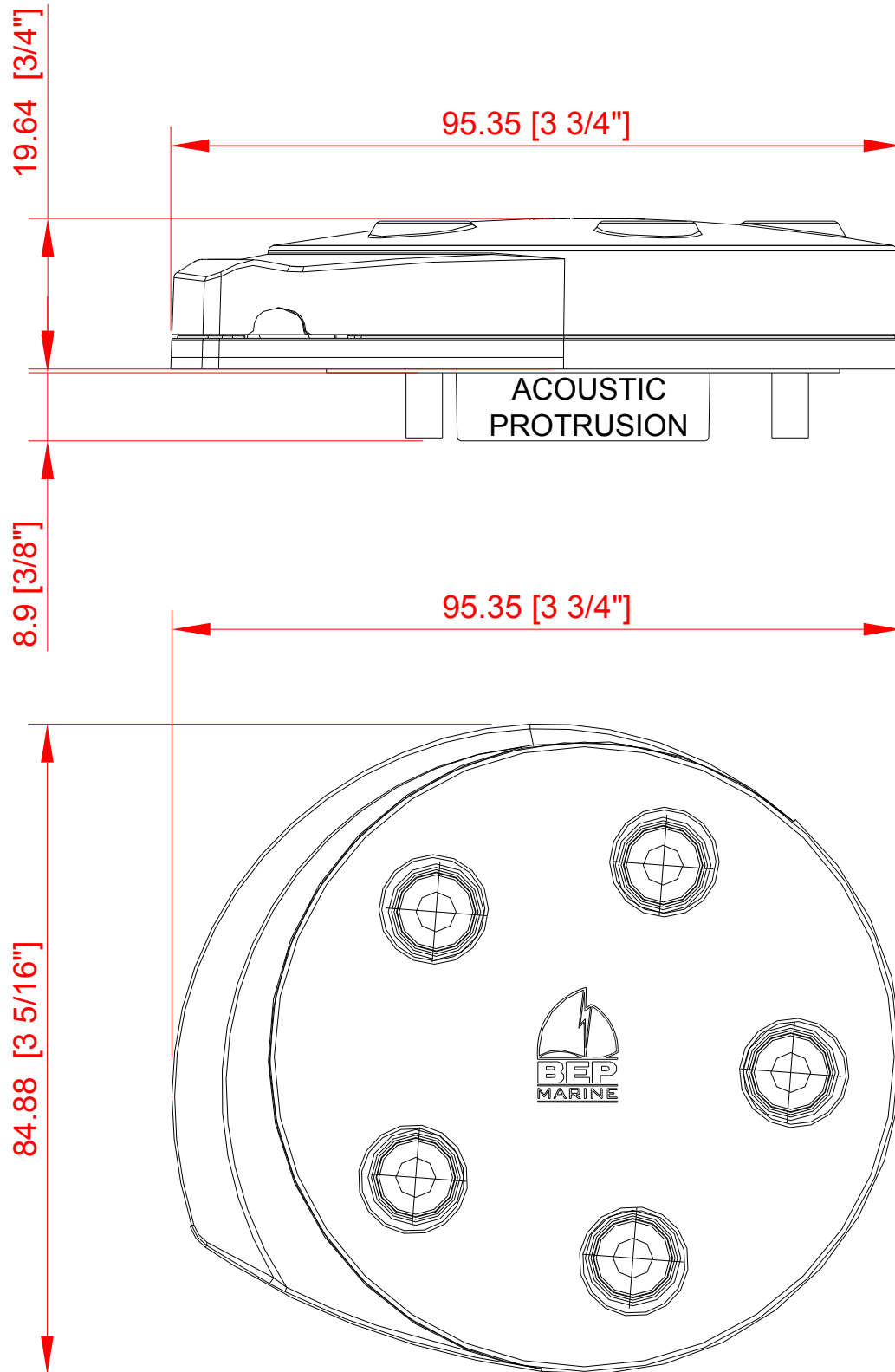

## 4. Mounting and Installation

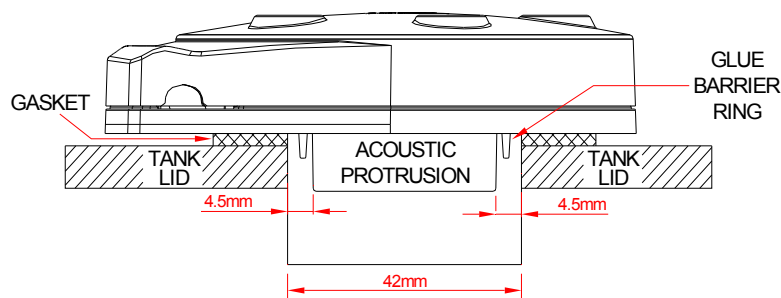
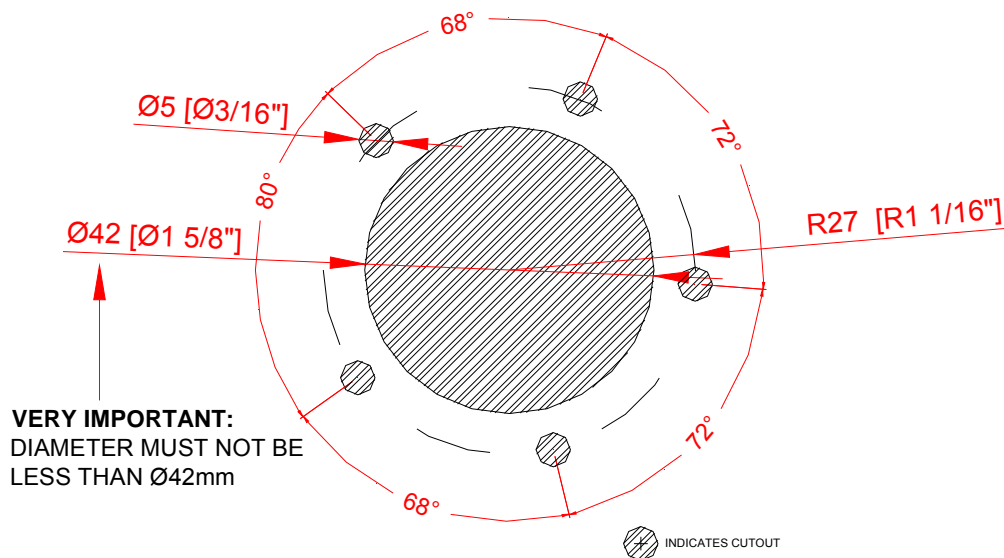

**IMPORTANT**  
SIDE WALLS OF ACOUSTIC PROTRUSION MUST BE NO  
CLOSER THAN 4.5mm TO THE TANK SIDES OF THE  
CUTOUT HOLE

- The acoustic protrusion should be positioned in the tank aperture in the centre of the hole. The protrusion should ideally be protruding into the tank and not be recessed in the hole. See drawing above.
- For tightening screws ensure base and washers are sitting flat. Tighten screw until screw head makes contact with the washer, and then tighten another 2 full turns.

*Maximum torque for the mounting screws is 0.5 Newton meter.*

**Note: Drawing is not to scale. Please use the tank gasket as a template and make sure the tank hole is 42mm.**

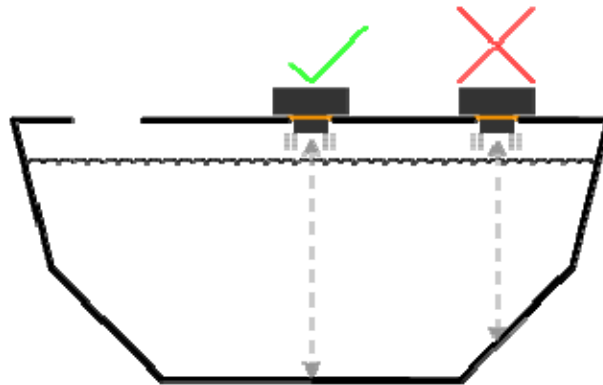

### Case 1

TS1 must be mounted at the deepest tank point!

*It is recommended the sender is mounted in the middle of the tank, this is particularly important on low or no baffled tanks that are mounted in moving vehicles or vessels. This allows the TS1 to average waves of fluid to the correct level when the depth is varying due to wave slop.*

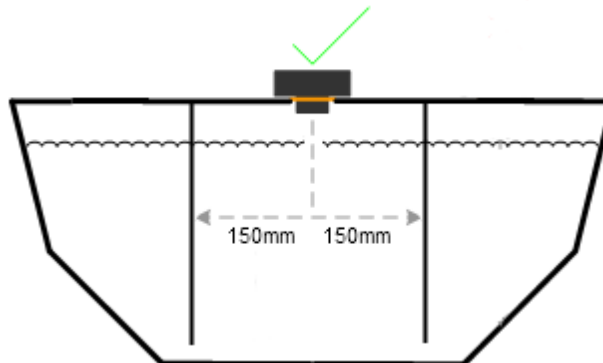

### Case 2

TS1 must be mounted at least 150mm from a vertical tank baffle, tank walls and piping.

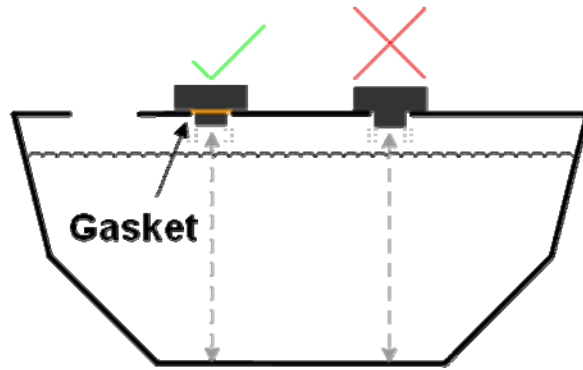

**Case 3**

Correct BEP Gasket must be used!

*Use 5 washers provided, washers must be placed under screw heads to prevent rubber lid damage.*

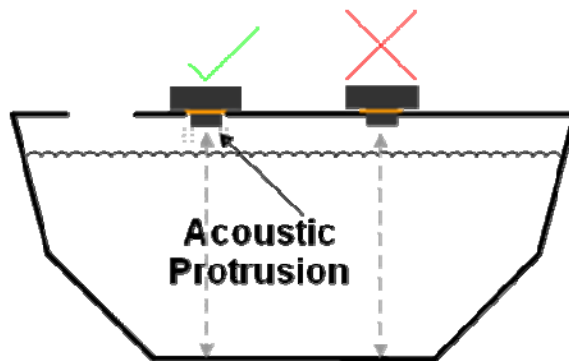

**Case 4**

Acoustic protrusion must not touch the tank frame!

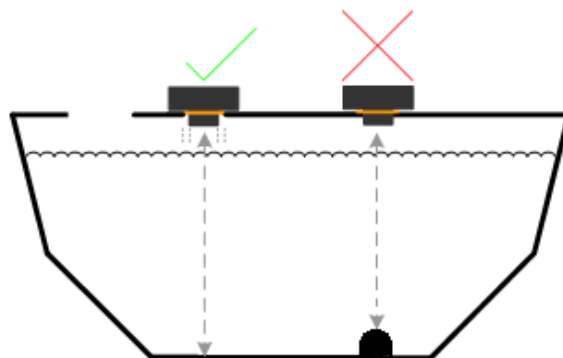

**Case 5**

TS1 must be mounted so it can see the bottom of the tank if the liquid is to be measured to the bottom.

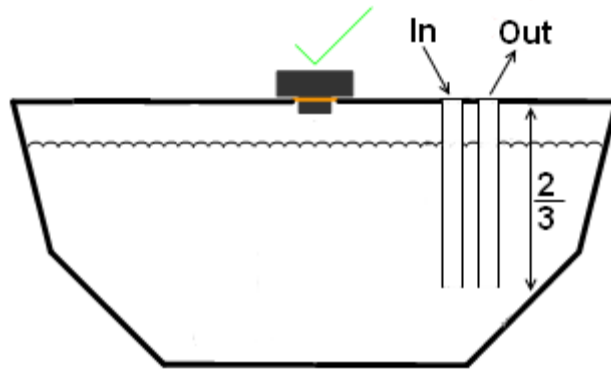

**Case 6**

Inlet and Outlet piping must go in at least  $\frac{2}{3}$  of the way in to the tank on grey and black water tanks to stop water turbulence when filling.

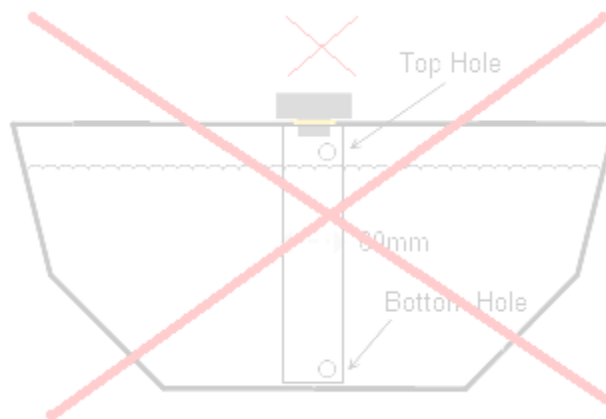

**Case 7**

Do not fit the TS1 with a tube.

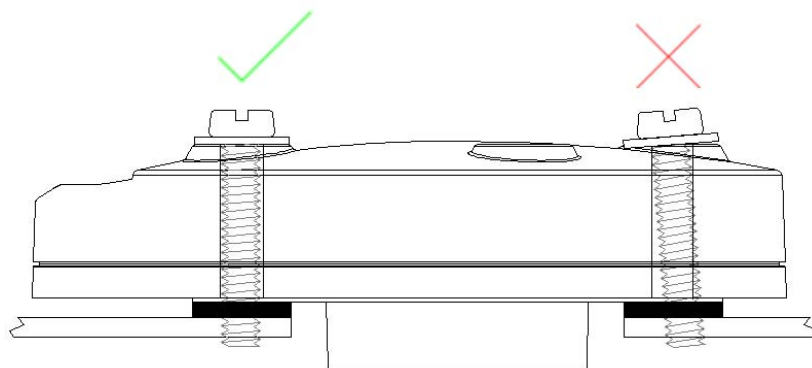

**Case 8**

Ensure bolts and mounting holes are aligned properly to keep plastic body isolated acoustically from tank. Do not over tighten the screws.



## 5. Wiring

Power must be removed before TS1 is connected to the system. Ensure wiring is correct or else damage may occur rendering the device inoperable.

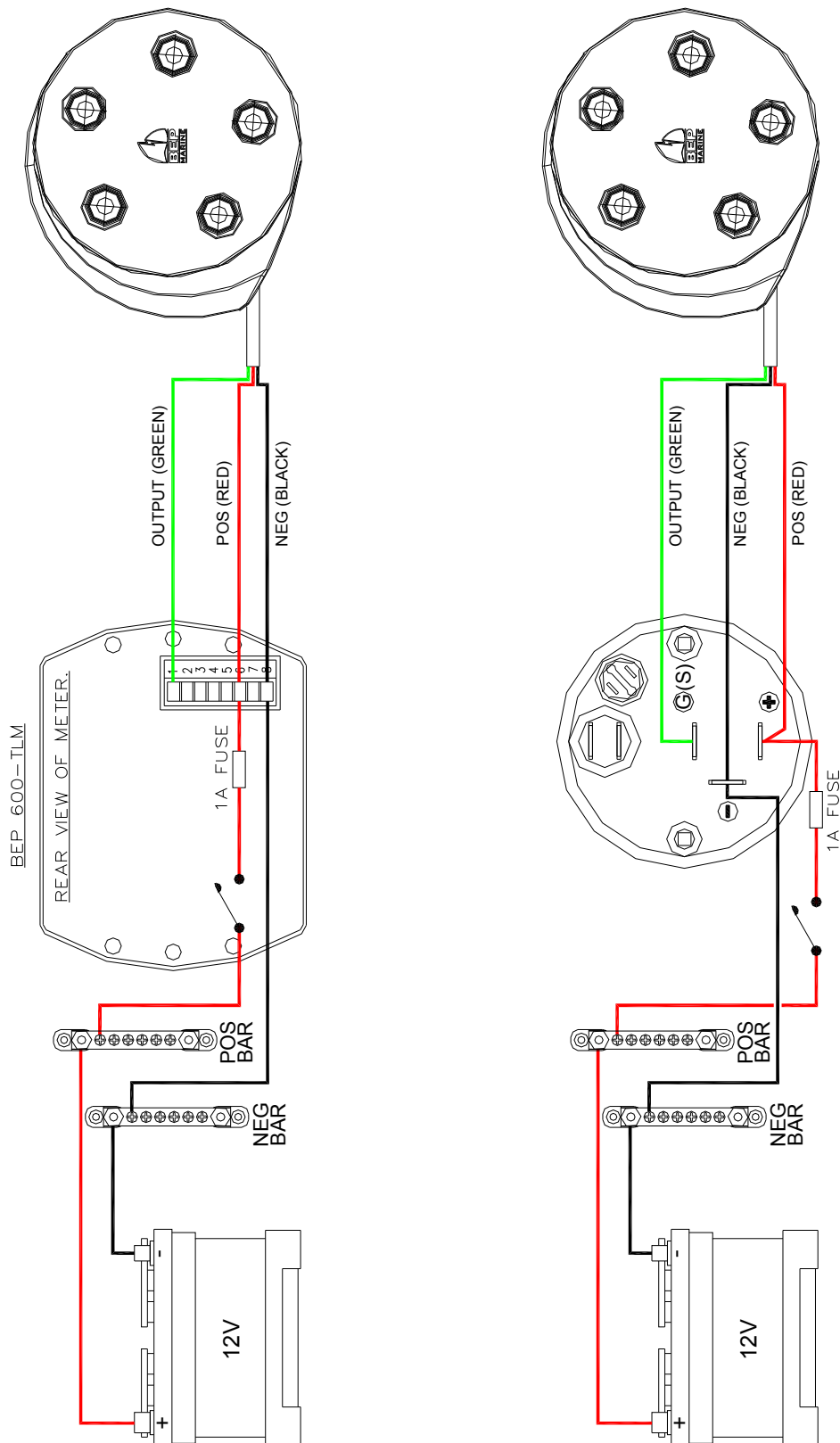

USE 24V RATED GAUGES FOR 24V SYSTEMS  
(GAUGE SHOULD HAVE DROPPING RESISTOR)

## 6. Programming and Setup

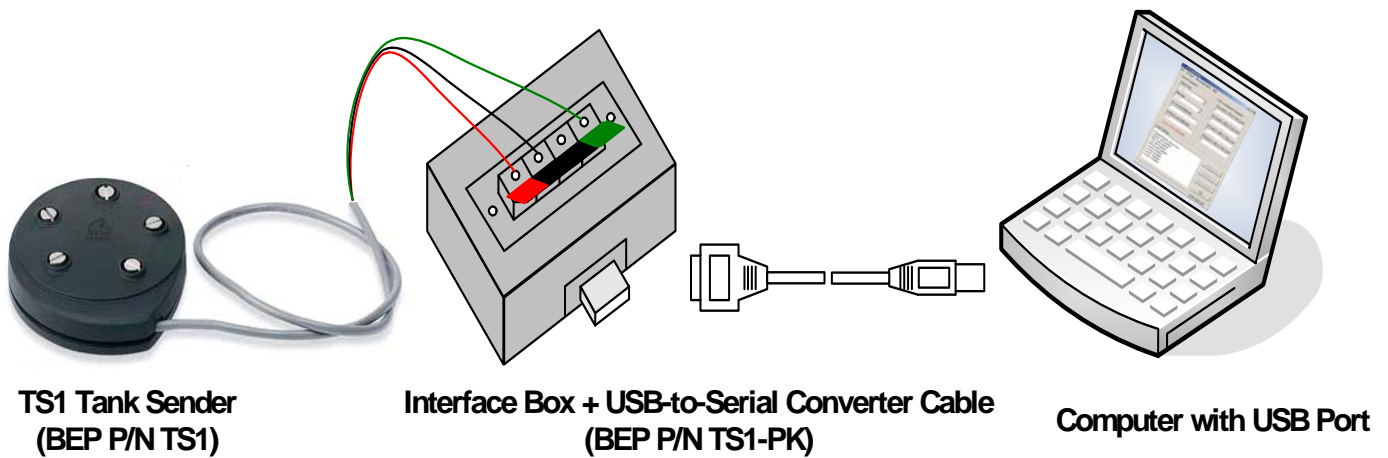

Please visit the BEP website for the programming software.

## 7. Problem Solving

### Water Tanks

After long periods of no use, condensation will build up on the roof of the water tank and the sender face. If the water droplets are large, the sender will not be able to read the contents of the tank accurately. This will clear with normal boat or RV use.

### Waste Tanks

Large amounts of foam bubble on the surface of the liquid caused by detergents or washing powders will result in the sender not receiving reflected sound pulses back from the liquid surface, instead these will be absorbed by the bubbles until they disperse. Then normal operation will resume.

## 8. Frequently Asked Questions

**Q:** *What is the signal update period?*

**A:** Signal is updated in real time.

**Q:** *Why is the tank level stuck on one value?*

**A:** When the sender cannot measure a valid tank level, the sender will recover the last good reading of the tank level from its own memory. This will be sent to the monitor until a new valid level is found.

**Q:** *Is the TS1 ignition protected?*

**A:** The TS1 is ignition protected and approved. It is fully potted.

**Q:** *On power up, the analogue gauge goes full scale then back to empty. After 5 seconds it shows the correct level.*

**A:** This is normal for a 10 – 180ohm analogue gauge.

**Q:** *On power up, the analogue gauge goes full scale and then back to the correct level.*

**A:** This is normal for a 240 – 33ohm analogue gauge.

**Q:** *The gauge is reading full all the time.*

**A:**

1. The most common problem is that the acoustic protrusion is touching the tank.
2. The incorrect gasket has been used specified gasket is a Cork/viton mix.
3. The sender is too close to the side of the tank.
4. There is an obstruction in the tank.
5. The mounting screws are not isolated acoustically from body (see. Case 8)

**Q:** *Is the sender sensitive to electrical interference. Should we use shielded cable?*

**A:** There is no need to use shielded cable, unless you are running a long distance and near appliance cables that radiate noise.

**Q:** *What is the maximum distance between sender and meter?*

**A:** 50 metres.

**Q:** *What support is there for the product?*

**A:** Updates will be placed on BEP website.

**Q:** *Why is the meter reading incorrect when tank is empty?*

**A:** There must be some fluid covering the bottom of the tank for sender to receive a valid return signal.

**Q:** *What is the beam angle of the sender?*

**A:** 300mm at 2M depth

**Q:** *Can I use a sealant with the TS1 and gasket*

**A:** Yes, but ensure sealant does not get on to protrusion. Also, do not over tighten screws for purpose of providing a tighter seal. The screws should be tightened until there is contact between screw head and washer, then another 2 full turns.

# **BEP**

**LEADING ELECTRICAL DESIGN**

BEP MARINE  
55 Paul Matthews Road,  
Albany, Auckland 0632  
New Zealand  
PO Box 101739 NSMC  
Phone (+649)4157261  
Fax. (+649)4159327  
[www.bepmarine.com](http://www.bepmarine.com)

E-mail: [enquiries@bepmarine.com](mailto:enquiries@bepmarine.com)  
Please visit our website for the latest International Distributor List