



BD compressor with a.c. and d.c. supply

»Connect wherever you are«

Introduction

Danfoss is pleased to introduce a new optional electronic unit for the BD35F and BD50F compressors.

The unit has a built in a.c./d.c. converter. The a.c. voltage range is from 85 V a.c. up to 265 V a.c., 50 /60 Hz.

The d.c. voltage range is from 9.6 to 31.5 V d.c.

The unit is therefore a true global voltage supply version.

Automatic detection of supply voltage which means no additional relay is required to shift between a.c. or d.c.

As accessory a small mounting plate will be offered which makes it possible to mount the electronic unit separately from the compressor. As an additional feature a 12 V d.c., 5 W lamp output has been introduced.

Samples will be available at the end of year 2004.

Features

The new electronic unit offers a lot of features such as

- Reduction of costs. No additional hardware is required
- Reduced total installation cost
- Reduced space in machine compartment
- High efficiency rate, > 90%
- Wide voltage range
- Lamp output
- Automatic voltage detection. No extra relay required for switching between a.c. and d.c.
- Remote mounting of electronic unit separately for compressor possible



Technical data

Input voltage a.c.	85 to 265 V a.c., 50/60 Hz
Input voltage d.c.	12 or 24 V d.c.
Safety cut out limits a.c.	75 and 270 V a.c.
Safety cut out limits d.c.	9.6 and 31.5 V d.c.
Output power	100 W
Ambient temperature	Maximum 55°C
Approvals	CE, UL and e-4
Insulation	Double
Lamp and fan output	12 V d.c., 5 W
EMI	Built in EMI filters
Connectors	6.3 mm, Rast 5

Code numbers

The following code numbers has been assigned
 Single pack 101N0500
 Industrial pack 101N0501

Electric wiring diagram

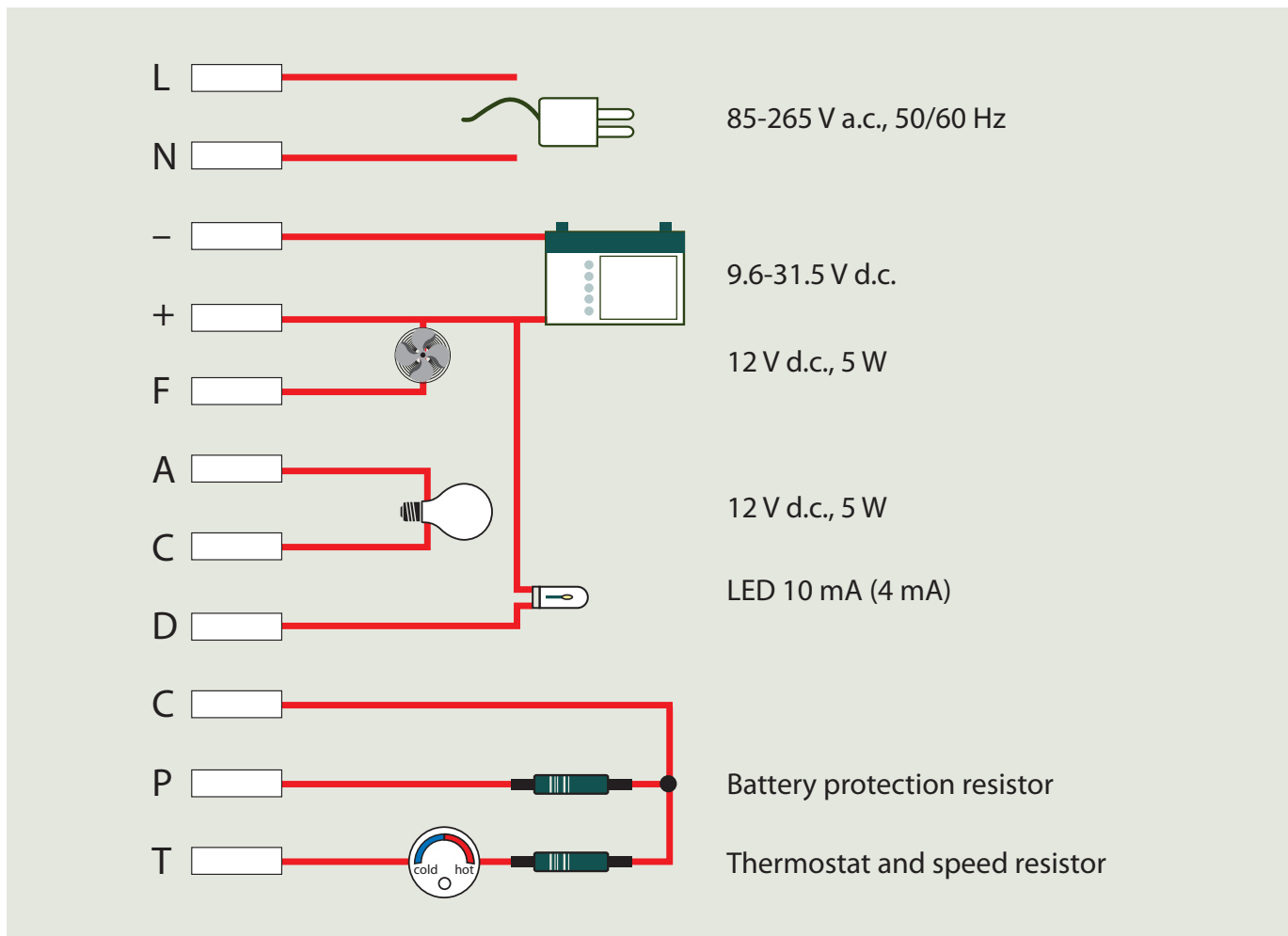

Danfoss Compressors GmbH

Mads-Clausen-Strasse 7
 Postfach 1443, D-24939 Flensburg
 Telefon: (0461) 4941-0
 International +49 461 4941-0
 Telefax: +49 461 44715
 Telex: 227 43 dancom d

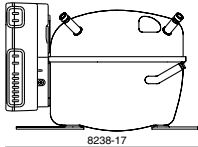

Instructions

Electronic Unit for BD35/BD50F Compressors,
101N0500, 12/24V DC & 100-240V AC 50/60Hz

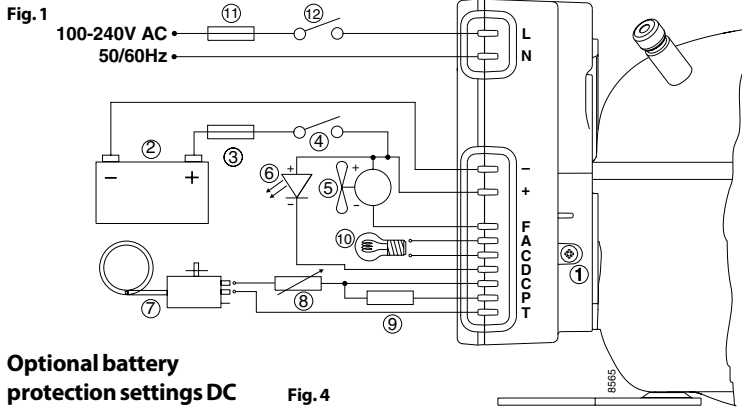

Optional battery protection settings DC

Fig. 4

Resistor (9) kΩ	12V cut-out V	12V cut-in V	12V max. Voltage	24V cut-out V	24V cut-in V	24V max. Voltage
0	9.6	10.9	17.0	21.3	22.7	31.5
1.6	9.7	11.0	17.0	21.5	22.9	31.5
2.4	9.9	11.1	17.0	21.8	23.2	31.5
3.6	10.0	11.3	17.0	22.0	23.4	31.5
4.7	10.1	11.4	17.0	22.3	23.7	31.5
6.2	10.2	11.5	17.0	22.5	23.9	31.5
8.2	10.4	11.7	17.0	22.8	24.2	31.5
11	10.5	11.8	17.0	23.0	24.5	31.5
14	10.6	11.9	17.0	23.3	24.7	31.5
18	10.8	12.0	17.0	23.6	25.0	31.5
24	10.9	12.2	17.0	23.8	25.2	31.5
33	11.0	12.3	17.0	24.1	25.5	31.5
47	11.1	12.4	17.0	24.3	25.7	31.5
82	11.3	12.5	17.0	24.6	26.0	31.5
220	9.6	10.9				31.5

Wire dimensions DC

AWG Gauge	Size Cross section mm ²	Max length* 12V DC operation		Max length* 24V DC operation	
		ft.	m	ft.	m
12	2.5	8	2.5	16	5
12	4	13	4	26	8
10	6	19.5	6	39	12
8	10	32.8	10	65.6	20

Fig. 2 *Length between battery and electronic unit

Wire dimensions AC

Cross section min. 0.75 mm² or AWG 18

Standard battery protection settings DC

12V cut-out V	12V cut-in V	24V cut-out V	24V cut - in V
10.4	11.7	22.8	24.2

Fig. 3

Compressor speed

Electronic unit	Resistor (8) Ω	Motor speed rpm	Contr.circ. current mA
101N0500	0	2,000	5
	277	2,500	4
	692	3,000	3
	1523	3,500	2

Fig. 5

ENGLISH

The electronic unit is a multi voltage device. It can be used in both 12V/24V DC and 100-240V AC 50/60Hz power supply systems. Max. voltage is 17V DC for a 12V DC system and 31.5V DC for a 24V DC power supply system. Max. voltage is 265V AC and min. 85V AC for an AC power supply system. Max. ambient temperature is 55°C. The electronic unit has a built-in thermal protection which is actuated and stops the compressor operation if the electronic unit temperature becomes too high (100°C / 212°F on the PCB). **Power consumption is limited to 100W. See datasheet BD50F for details.**

Installation (Fig. 1)

Connect the terminal plug from the electronic unit to the compressor terminal. Mount the electronic unit on the compressor by snapping the cover over the screw head (1).

Power supply (Fig. 1)

DC: The electronic unit must always be connected directly to the battery poles (2). Connect the plus to + and the minus to -, otherwise the electronic unit will not work. The electronic unit is protected against reverse battery connection.

For protection of the installation, a fuse (3) must be mounted in the + cable as close to the battery as possible. It is recommended to use 15A fuses for 12V and 7.5A fuses for 24V circuits. If a main switch (4) is used, it should be rated to a current of min. 20A. The wire dimensions in **Fig. 2** must be observed. Avoid extra junctions in the power supply system to prevent voltage drop from affecting the battery protection setting.

AC: The wires must be connected to the terminals marked **L** and **N** on the electronic unit. Nominal voltages from 100 to 240 VAC 50/60Hz. Upper safety cut-out limit = 270V AC and lower limit 80V AC. A 4A fuse (11) must be mounted in the live (**L**) cable to protect the installation.

If a main switch (12) is used, it should be rated to a current of min. 6A. The wire dimensions must be min. 0.75 mm² or AWG 18. NB: *No earth* connection is needed as the electronic unit is equipped with double insulations.

General: Both the AC and the DC power supply can be connected to the electronic unit at the same time. In this case, AC will be preferred power supply source. If the AC power supply is disconnected on a 12V DC supply system, a time delay of 1 min. will be activated before the compressor continues on DC power supply. If AC power supply is established there will be no delay in compressor operation, when power supply shifts from DC to AC.

Battery protection (Fig. 1)

The compressor is stopped and re-started again according to the decided voltage limits measured on the + and - terminals of the electronic unit. The standard settings for 12V and 24V power supply systems appear from **Fig. 3**.

Other settings are optional if a connection which includes a resistor (9) is established between terminals **C** and **P**. See manual.

Thermostat (Fig. 1)

The thermostat (7) is connected between the terminals **C** and **T**. Without any resistor in the control circuit, the compressor will run with a fixed speed of **2,000 rpm** when the thermostat is switched on. Other fixed compressor speeds in the range between 2,000 and 3,500 rpm can be obtained when a resistor (8) is installed to adjust the current (mA) of the control circuit. Resistor values for various motor speeds appear from **Fig. 5**.

Fan (optional, Fig. 1)

A fan (5) can be connected between the terminals + and **F**. Connect the plus to + and the minus to **F**. Since the output voltage between the terminals + and **F** is always regulated to 12V, **a 12V fan must be used for both 12V and 24V power supply systems.** The fan output can supply

a continuous current of **0.5A_{avg}**. A higher current draw is allowed for 2 seconds during start.

Lamp (optional, Fig. 1)

A 12V DC 5 Watt lamp (10) can be connected between the terminals **A** and **C**. The output voltage between the terminals **A** and **C** is always regulated to 12V DC. **A 12V DC lamp must be used for both 12V and 24V power supply systems.** The lamp output can supply a continuous current of **0.5A_{avg}**.

LED (optional, Fig. 1)

A 10mA light emitting diode (LED) (6) can be connected between the terminals + and **D**. If the electronic unit records an operational error, the diode will flash a number of times. The number of flashes depends on what kind of operational error was recorded. Each flash will last ¼ second. After the actual number of flashes there will be a delay with no flashes, so that the sequence for each error recording is repeated every 4 seconds.

Number of flashes	Error type
5	Thermal cut-out of electronic unit (If the refrigeration system has been too heavily loaded or if the ambient temperature is high, the electronic unit will run too hot).
4	Minimum motor speed error (If the refrigeration system is too heavily loaded, the motor cannot maintain minimum speed 1,850 rpm).
3	Motor start error (The rotor is blocked or the differential pressure in the refrigeration system is too high (>5 bar)).
2	Fan over-current cut-out (The fan loads the electronic unit with more than 1A _{peak}).
1	Battery protection cut-out (The voltage is outside the cut-out setting).