

**2500 VWC VWCLP
MANUAL**

Copyright: Maxwell Marine International Ltd.
All rights reserved
Patents pending
Printed in New Zealand

Maxwell Marine International Ltd. reserves the right
to make engineering changes to all products without
notice. Illustrations and specifications not binding as
to detail.

P19163 Rev. 7.00
27/07/2010

Contents

1.0	INTRODUCTION	2
1.1	PRE-INSTALLATION NOTES	2
1.2	PRODUCT VARIATIONS	3
1.3	SPECIFICATIONS	4
2.0	INSTALLATION	5
2.1	SELECTION OF POSITION FOR THE WINDLASS	5
2.2	PREPARATION OF MOUNTING AREA	6
2.3	PREPARATION OF THE WINDLASS	7
2.4	INSTALLING THE WINDLASS	7
2.5	POWER CONNECTIONS TO DC MOTOR	9
2.6	INSTALLATION OF CONTROLS	10
2.7	NOTE TO BOAT BUILDER	10
3.0	USING THE WINDLASS	11
3.1	PERSONAL SAFETY WARNINGS	11
3.2	LOWERING THE ANCHOR UNDER POWER	12
3.3	RETRIEVING THE ANCHOR UNDER POWER	12
3.4	LOWERING THE ANCHOR UNDER MANUAL CONTROL	12
3.5	RETRIEVING THE ANCHOR UNDER MANUAL CONTROL	13
3.6	OPERATING THE WARPING DRUM INDEPENDENTLY	13
4.0	MAINTENANCE	14
4.1	EVERY TRIP	14
4.2	EVERY THREE MONTHS	14
4.3	EVERY YEAR	14
4.4	RECOMMENDED LUBRICANTS	15
4.5	SPARE PARTS	16
4.6	TOOLS FOR MAINTENANCE	16
5.0	TROUBLESHOOTING	17
	APPENDIX A - Dimensional drawings	18
	APPENDIX B - Spare Parts	20
	APPENDIX C - Electric Wiring schematics	23
	APPENDIX D - Warranty Form	25

1.0 INTRODUCTION

1.1 PRE-INSTALLATION NOTES

- Read this manual thoroughly before installation and using the windlass. Failure to adhere to the correct procedures, recommendations and guidelines described in this Owner's Manual may invalidate the warranty.
- Be mindful that the correct selection of windlass for each application, together with correct installation, normal care in use and maintenance, are essential for long life and reliable performance.
- Inspect your windlass carefully when unpacked. Any damage or lack of components should be reported immediately to your Maxwell distributor.
- The windlass is supplied with chainwheel, as specified on purchase order. Make sure it is the appropriate one for the chain being used on board. Correct fit of the chain to chainwheel is essential for reliable and safe operation of the windlass. This can be guaranteed only when calibrated chain to a recognised international standard is used and the chain is correctly identified to Maxwell, or if a chain sample is provided to Maxwell to develop a custom chainwheel.
- The windlass is designed for use in conjunction with chain stopper of the appropriate size. Their use is an important safety feature.
- For side pocket anchors, a chain roller should be installed above the hawse pipe to ensure smooth and quiet travel of the chain from deck to hawse pipe. The roller requires a central groove to align chain and flat faces (for longer chains) to support and avoid bending the chain links.
- The connection of the power lines and control circuitry to the windlass must be done by skilled technicians, to ensure reliable and safe operation of the windlass.

1.2 PRODUCT VARIATIONS

There are two options of above-deck arrangements or “topworks”.

The types of topworks are:

VWC - vertical windlass with chainpipe

VWCLP - vertical windlass with chainpipe, low profile

Each of the above topworks is available as clockwise or anticlockwise configuration (see description of Definition of rotation in Section 2.1).

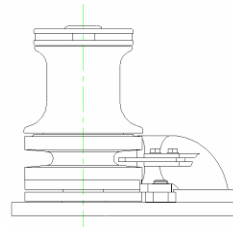

Picture 1.1
VWC Topworks

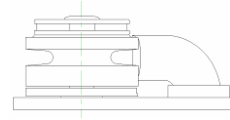

Picture 1.2
VWCLP Topworks

Chainwheels

The chainwheel numbers consist of two parts: main part number and suffix, for example 3231-001.

The main part number refers to the type of chainwheel and the suffix refers to size and type of chain.

Please refer to your closest Maxwell Marine agent or distributor (Appendix D), who will select the correct replacement chainwheel for your chain.

1.3 SPECIFICATIONS

Electric DC Drive 24V	
Line speed at 350kg load (771 lbs)	14.5m/min (48 ft/min)
Maximum pull capacity	1135kg (2500lb)
Current at 350kg load	100A
Current at stall	380A
Motor power	1.5kW (2HP)
Weight of capstan	41kg (90lb)

! Rated capacity and chain speed is based on the chainwheel for 10mm chain. The performance may vary by up to $\pm 10\%$ when other size chainwheels are used.

2.0 INSTALLATION

2.1 SELECTION OF POSITION FOR THE WINDLASS

Windlasses of this size will often be installed in pairs, giving an emergency backup in the event of mechanical or electrical failure. In this case one of the windlasses will normally be retrieving anchor running clockwise and the other anticlockwise (Picture 2.1).

Position of the windlass should be selected together with positions of hawse pipe and spurling pipe.

The deckplate should be installed pointing with its narrower end in the direction of the incoming chain. That allows the chain to have maximum engagement with the chainwheel.

Allow the chain a straight run from the bow roller to the chainwheel with no more than a 2° deviation from horizontal (Picture 2.2).

The bow roller should have a vertical groove to suit the profile of the chain. Its centre line should be tangential to the chainwheel. This will align the chain so that it enters the chainwheel without twisting.

The fitting of a chain stopper is essential to take the load off the windlass while the vessel is at anchor. It must be correctly aligned with the direction of chain and installed at appropriate height to avoid the chain rubbing over chain stopper body or pawl. Make sure the chain stopper clears the anchor shank.

A tensioner device to tension the anchor into its pocket is recommended. If the anchor is not snug in the pocket, it could cause damage to the pocket in a heavy seaway.

Ensure a minimum of 800mm (32") clearance between the end of spurling pipe and the chain piled up in the chain locker (Picture 2.3). This will assist kinks, which may develop in outgoing chain, to shake free.

The chain must gravity feed into the locker. If the chainpipe cannot be positioned directly over the locker, a heavy wall pipe can be used to direct the chain to the required area. It is important that the chain slips through the pipe easily; completely unaided, sharp corners should be avoided. It may be necessary to provide the pipe with a bell mouth or to bell mouth the entrance to the chainpipe from the locker to assist the free flow of the chain from the locker.

The chain locker must be of such a size and shape that the chain will heap up and feed out naturally without fouling.

If it can be arranged, the chain locker bulkhead should pass between the chainpipe outlet in the deckplate and the gearbox. This will keep the gearbox, motor and power lines dry and away from flaying chain. Access for servicing from inside the cabin area can usually be arranged through a locker.

Note that the gearbox can be indexed through a number of different angles in relation to the windlass deckplate (Picture 2.4). Be sure to select

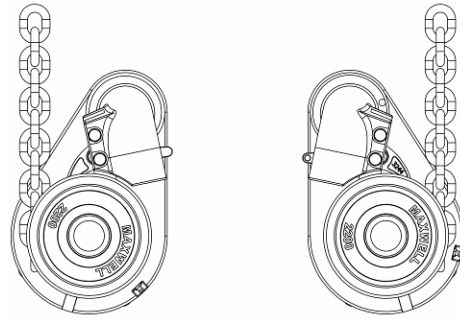

Anticlockwise topworks Clockwise topworks
Picture 2.1

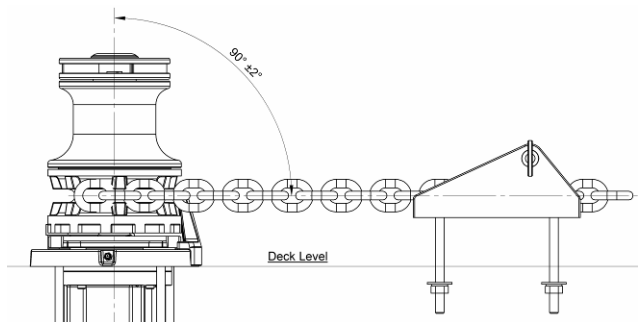

Picture 2.2
Correct angle of chain and height of chain stopper

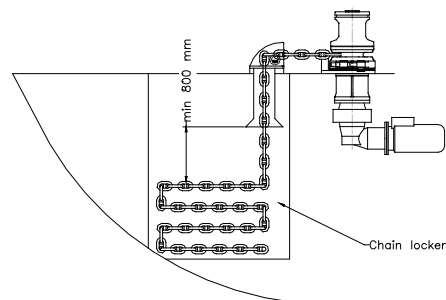

Picture 2.3
Recommended free space in chain locker

the most convenient arrangement at installation and ensure incoming chain well clears the gearbox, motor and power supply lines.

To ensure safe position of the operator while tailing from the warping drum, footswitches should be positioned at least 700mm (28") away from the windlass.

The below deck portion of the footswitch should not be exposed to water or wet environment and the breather holes must be kept clear. The arrows on the footswitches should be arranged to indicate the direction of operation.

The motor starter should be located in a dry area in close proximity to the windlass. It must not be located in the wet environment of the chain locker.

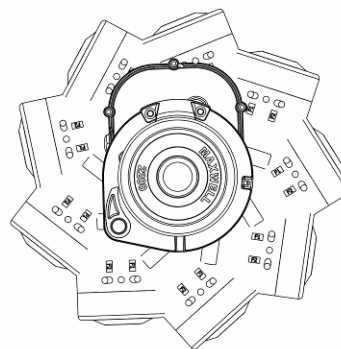

Picture 2.4

Positions of drive, relative to topworks

2.2 PREPARATION OF MOUNTING AREA

It is of paramount importance that the vessel has sufficient deck reinforcing and total structural strength to sustain the loads that can be transmitted to the mounting area of the windlass and chain stopper. This should be equal to the loading of the equipment to beyond breaking strength of the chain. The mounting area for the windlass must be perfectly flat and rigid. Structural grade fillers can be used to level this area if initial flatness is inadequate.

Mounting area for the chain stopper should be prepared at the same time. The chain stopper has to be installed at an appropriate height to ensure that chain lays horizontally when it comes out of the chain stopper and into windlass. Maximum allowed angle deviation in vertical plane is $\pm 2^\circ$.

If hawse pipe is angled outboard from deck to anchor pocket, the chain stopper should also be angled by half of the angle of the hawse pipe (Picture 2.4). That will help to reduce twisting of the chain between the chain stopper and the windlass and ensure good fit of the chain into the chainwheel. The chain stopper can be installed vertically if the hawse pipe angle is less than 4° .

A deck cutout detail drawing is enclosed with these instructions to assist in marking out all the drilling and cutting required for installing the windlass. Before drilling and cutting, check the marked out area is dimensionally correct and make any necessary corrections.

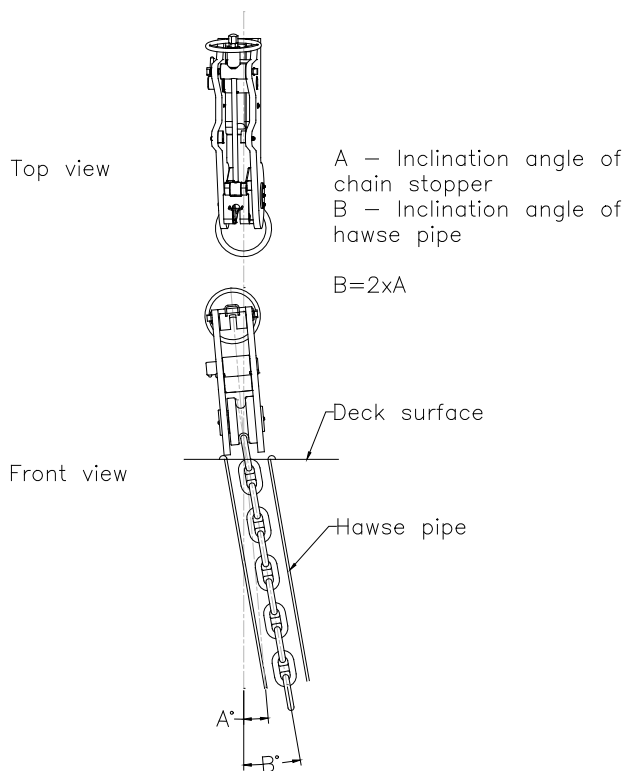

Picture 2.4

Installation angle of chain stopper

2.3 PREPARATION OF THE WINDLASS

Remove windlass from its packing case. Disassemble it in the following order (refer to drawing in Appendix B):

- Remove the black Plastic Cap from the top of the windlass, taking care not to damage the chromed surface.
- Undo and remove the Retaining Screw and Retaining Washer under the Cap, using a flat screw driver.
- Undo and remove Clutch Nut.
- For VWC models only - remove Drum.
- Remove upper Clutch Cone and Disc Spring.
- Undo Screws that retain Chain Stripper and remove it.
- Remove Chainwheel, Disc Spring, Lower Clutch Cone, Key, Retention Clips, Emergency Crank Collar and Wave Spring.
- Undo Screws and remove the Deckplate.
- Refer to Appendix B of this Manual and identify all parts. If any parts are damaged or missing, contact your Maxwell distributor. Some smaller parts might not be assembled on the windlass by the factory, but supplied in a plastic bag in the packing case.

Maxwell strongly recommends generous application of a high quality anti-corrosive paste or coating to the mating sections of main shaft, drive key, flanges, screw threads, dowels and other surfaces that are likely to seize after being in contact for a prolonged period of time.

Also ensure anti-corrosive coating is liberally applied to the inside wall of the spacer tube.

2.4 INSTALLING THE WINDLASS

Refer to the drawing in Appendix B for help with identifying components and installing them correctly. Extra care should be exercised when handling polished parts to avoid any damage to polished surfaces.

When assembling the parts, apply an anti-seize compound generously over all screw threads, keys and keyways, main shaft and inside the spacer tube. Proceed with installation in the following order:

- After cutting holes for the windlass in the deck, apply an appropriate bedding/sealing compound and bolt the deckplate to the deck using mounting studs, washers and nuts. Tighten them evenly to 35-40 Nm (25-30 ft lb). The chainpipe and the pawl, if should already be assembled to the deckplate.
- Offer up, from below deck, the drive assembly sliding the main shaft through the deckplate, taking care not to damage the deck bearing.
- After aligning them correctly, bolt the deckplate and spacer tube together, from above deck,

! When installing the Capstan, the shaft MUST be coated in Shell Nautilus NLG12 Marine Grease, Castrol Boating Grease, Vavoline Val Plex EP or equivalent grease.

using the 3/8" hex head screws and spring washers. Tighten them evenly to 35-40 Nm (25-30 ft lb).

- Re-check that the position of the drive assembly is satisfactory and convenient for connecting power supply lines to the motor. Also, make sure that the drive is not in the way of chain coming into the locker.
- If a chain counter is used, its sensor should be fitted into the Ø15mm hole in the deckplate, currently covered with a plastic plug. Make sure the deck is drilled below for the sensor cable. See brochure supplied with chain counter for detailed assembly instructions.
- Slide the emergency crank collar over the main shaft and then the spring and washer on top of it.
- Insert the two retention clips into the groove in the main shaft. Apply some grease to help keep them in position.
- Apply anti-seize compound generously over the main shaft and keyway. Insert key into the lower keyway on the main shaft.
- Assemble the lower clutch cone making sure it sits nicely on the retention clips (picture 2.5). Apply Lithium based marine grease generously to the conical surface of the clutch cone, to assist with free falling the anchor.
- Put the disc spring on top of the lower clutch cone, turning its smaller diameter towards the clutch cone (picture 2.6).
- Install Chainwheel and the remaining disc spring on top of it, turning its bigger diameter towards the Chainwheel.
- Install Upper Clutch Cone, after applying marine grease to its conical surface (see picture).
- Assemble drum on top of the clutch cone (VWC models only).
- Assemble clutch nut.
- Put retaining washer on top of the main shaft and secure it with the countersunk screw.
- Insert plastic cap into the clutch nut.

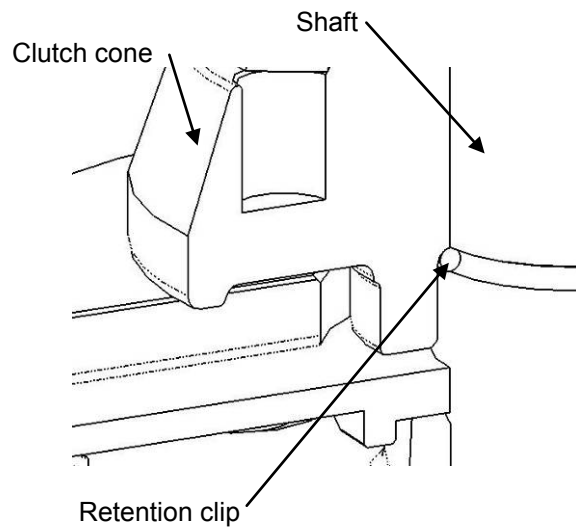

Picture 2.5
Retention Clip Assembly

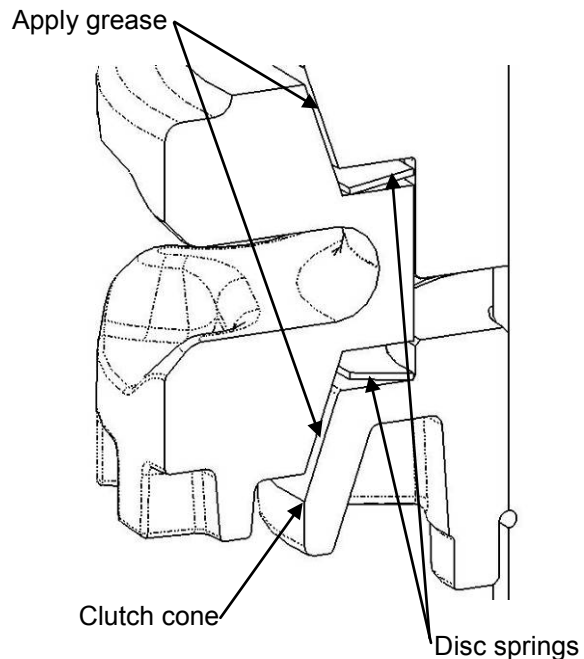

Picture 2.6
Greasing clutch cones and disc spring orientation

2.5 POWER CONECTIONS TO DC MOTOR

The main power system is a two cable, ungrounded, fully insulated, negative return system. The motor is of the isolated earth type. This system is selected to minimise electrolytic corrosion problems.

The DC motor has three power terminals, marked "F1", "-" and "F2". Terminal "-" should be connected directly to "-" terminal on the battery, see wiring schematic in Appendix C. Terminal "F1" is for clockwise rotation of the motor and "F2" is for anticlockwise rotation. Depending on the desired direction of rotation, one of these terminals should be connected to solenoid.

See Table 2.1 to select the appropriate cable size for power supply. The recommendation assumes that the cable insulation has a minimum temperature rating of 90°C and sizes allow for a maximum 10% voltage drop over the total length.

Cable lengths given are from the battery terminal to the terminal on the motor, via the solenoid box, and then back to the battery.

Where a portion of cable runs through the engine room, a size increase should be made as indicated.

After connecting the cables, spray all terminals with anti-corrosive waterproof coating, "CRC 3013 Soft Seal" or equivalent.

! When tightening the cables to the motor, ensure the lower nut is secure against turning when tightening the upper nut. This will prevent damage occurring within the motor.

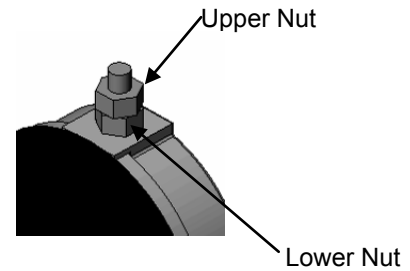

Picture 2.7
Motor Connections

24v Systems				
Total Cable Length from battery to winch then back to battery	Wire Size		Engine Room Wire Size Correction*	
	mm ²	AWG	mm ²	AWG
Up to 19m (62')	14	6	16	5
From 19m - 23m (62' - 75')	16	5	22	4
From 23m - 30m (75' - 98')	22	4	-	-
From 30m - 98m (98' - 114')	26	3	-	-
From 98m - 47m (118' - 154')	34	2	-	-

Table 2.1
Recommended wire sizes

2.6 INSTALLATION OF CONTROLS

The windlass can be operated using:

- Deck mounted footswitches
- Hand held pendant controller (single or dual speed)
- Helm switch
- Chain counter

These control accessories are available from Maxwell customised to suit your windlass.

It is the choice of the designer/builder to use one, two or all three of these controls. They are wired in parallel to the directional valve (for hydraulic windlasses) or to the starter unit (for electric windlasses). The controls can work on 12 or 24V power supply.

If footswitches are used, then an isolator switch for them must be installed in the wheelhouse, to prevent operating the windlass by someone accidentally stepping on the footswitch.

Hand held pendant controller is often the most convenient way of operating the windlass. Maxwell offers several variations of pendants, including single speed, dual speed, single pendant for running a pair of windlasses, pendants with auxiliary buttons which can be used for starting chain wash system, hydraulic pump etc. They are supplied with a plug on the other end of cable and a matching waterproof socket, which should be installed on a convenient location on the deck.

All units are supplied with detailed wiring instructions to assist installation.

Refer to wiring schematics in Appendix C for control circuits. All control wiring should be done using no smaller than 1.5mm² wire (AWG 16).

A manually re-settable, ignition proof 3A breaker or fuse should be installed on the power supply line for controls, within 1m (40") from the main breaker/isolator. These requirements are mandatory to meet USCG, ABYC and NMMA rules.

After connecting the power lines, spray all ports and fittings with anti-corrosive waterproof coating "CRC 3013 Soft Seal" or equivalent.



Picture 2.9

Pendant controller for operating two windlasses

2.7 NOTE TO BOAT BUILDER

Experience has shown that, on long ocean deliveries, sulphur from the ship's exhaust can settle on polished surfaces, which can affect the quality of the finish.

Please ensure that, upon completion of installation, the windlass is treated with suitable corrosion protective coating ("CRC 3097 Long Life") and wrapped in plastic film. This ensures that your customer receives the windlass from you in the same top quality condition as you received it from Maxwell.

3.0 USING THE WINDLASS

3.1 PERSONAL SAFETY WARNINGS

- As with all load carrying equipment, the consequences of heavy overload, neglect or misuse may be unexpected failure and exposure of crew and/or vessel to risk. Operate the windlass with extreme care at all times.
- Before testing the windlass for the first time, check that all the wiring has been done correctly.
- When using the windlass at all times practice good seamanship and adhere to the following rules in order to avoid any likelihood of injury or accident.
- At all times keep hands, feet, loose clothing, cordage and your hair WELL CLEAR.
- Never operate the windlass from a remote station without maintaining a clear view of it and having made sure that everyone is well clear of the windlass, anchor and chain.
- Never use the windlass under power with the clutch handle inserted into clutch nut or emergency crank collar.
- When engaging the pawl while chain is running, keep fingers away from the chain. Use clutch nut lever, underneath and guarded by the chainpipe.
- Always motor up to the anchor position before retrieving it from the bottom. Do not use the windlass to pull the boat to the anchor.
- If the anchor is fouled, do not use the windlass to break it out. With the chain stopper taking the load, use the boat's engine to break the anchor loose.
- When lowering the anchor under manual control, use the band brake or friction clutch (if fitted) to control the speed of the chain. Never lower the anchor without maintaining safe chain speed.
- When the windlass is not in use, make sure the power supply is isolated, making an accidental operation thereby impossible.
- Do not use the windlass as an anchoring point for the chain. Engage the chain stopper when the windlass is not in operation.
- Never proceed at speed without first ensuring that the chain stopper is engaged. Also engage the tensioner to keep the anchor snug in the pocket.
- When using the windlass, do not switch immediately from one direction of rotation to the other, without waiting for windlass to stop. Abuse is not covered by warranty.

3.2 LOWERING THE ANCHOR UNDER POWER

- Ensure the clutch is fully engaged by inserting the clutch nut lever in one of the slots on the clutch nut, and turning clockwise firmly. The windlass is equipped with a friction clutch, so it can be engaged in any position (there is no need to match the position of the opposite sides of the clutch before engaging it).
- Remove clutch handle.
- Release pawl.
- Disengage chain stopper and chain tensioner (if fitted). To disengage the chain stopper pawl the windlass may require momentary jogging in the up direction.
- The windlass may now be lowered under power by operating either the hand held pendant control, helm switch or footswitch.
- When finished, turn off the isolator switch for the controls.

! As a safety feature the windlass will continue to operate up or down only while the operating button, toggle switch or foot switch is held in the engaged position.

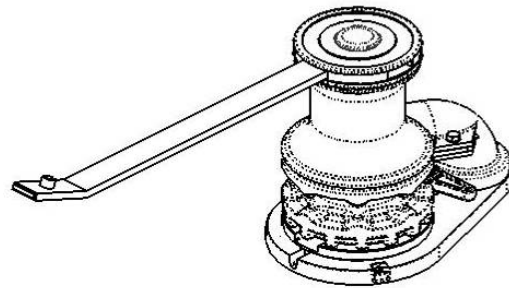

Picture 3.1
Engaging the clutch

3.3 RETRIEVING THE ANCHOR UNDER POWER

- Ensure clutch is engaged and pawl is released.
- Remove clutch handle.
- Release chain stopper and/or tensioner.
- The windlass may now be operated to raise the anchor.
- After retrieving the anchor engage chain stopper and/or tensioner.
- Turn off the isolator switch for the controls.

! It is regarded as sound practice to motor over the anchor position and so reduce chain tension. This will also help the anchor to break out, reduce the power consumption and reduce load on the windlass and deck gear.

! Care should be exercised when docking the anchor to avoid damage to the anchor pocket. Jog in the last meter (3-4') of the chain carefully seating the anchor home.

3.4 LOWERING THE ANCHOR UNDER MANUAL CONTROL

This method will normally be employed to lower the anchor quickly, to lower it in "quiet ship" and in emergencies (power loss or control failure). Proceed as follows:

- Tighten the clutch.
- Release the chain stopper and/or chain tensioner. If the anchor has to be lowered in case of power loss and pawl on the chain stopper is engaged and under tension (by chain), to release it, pull the chain in slightly, either by power or manually. If there is too much slack in the chain, it might be necessary to jog the windlass up under power or use the emergency crank lever. If doing that, make sure the clutch is still engaged, for safety reasons.
- Slowly disengage the clutch by turning the clutch nut anticlockwise. Regulate the speed by tightening to slow (clockwise) or easing (anticlockwise) to increase speed
- When the required amount of chain is out, tighten the clutch nut firmly.

! It is considered potentially dangerous to allow the chain to free fall in an unrestricted manner - always control the chain speed.

! If jogging under power, ensure the lever is removed first.

3.5 RETRIEVING THE ANCHOR UNDER MANUAL CONTROL

The windlass is equipped with a cranking mechanism to retrieve the anchor in case of emergency. It involves operating the windlass manually under heavy load and extra care must be exercised when using it to avoid injury.

To use proceed as follows:

- Check that the chain stopper is engaged. If a chain stopper is not fitted, ensure that the pawl is engaged with the chainwheel.
- Insert the clutch nut lever in the clutch nut and release clutch by turning the clutch nut in anticlockwise direction.
- Insert the clutch nut lever (the end with spigot) into the emergency crank collar and engage the spigot with one of the dogs in the chainwheel in the furthestmost forward position (Picture 3.2).
- Pull the lever back as far as possible, bringing the chain in. Engage the pawl and ease off the lever.
- Push lever to furthestmost forward position and re-engage with the chainwheel.
- Repeat the cycle until the anchor is retrieved. It is a very slow process and should be used only in emergencies.

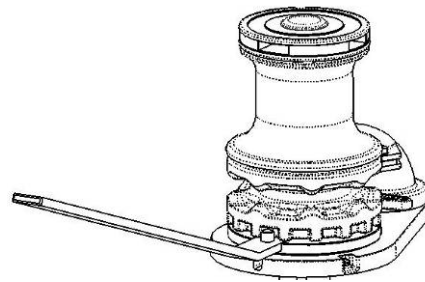

Picture 3.2

Using emergency crank mechanism

3.6 OPERATING THE WARPING DRUM INDEPENDENTLY

This is applicable to VWC models only. The drum can be operated independently of the chainwheel and can be used to manage docking lines or a second anchor. To use in this way, proceed as follows:

- Engage the chain stopper and/or the pawl.
- Fully disengage the clutch as described in Section 3.4.

The drum may now be operated independently of the chainwheel. Maxwell recommends all warping operations be controlled by the footswitch. This makes it a one-person operation and offers better control of the capstan in case of emergency.

Take several turns of the warping line around the drum and pull on the rope tail with sufficient manual force to provide good grip of the line to the drum, whilst operating the footswitch. Make sure the drum is operated in the same direction as the line is wrapped around it.

Do not engage more turns on the drum than are necessary to accomplish the task. Whilst docking, wind and tide can impose sudden and excessive line tension. It is recommended to allow slipping to occur at the drum. This will protect the capstan, docking lines and vessel from damage.

- ! While handling docking lines with the capstan, everybody has to stay well clear of the lines and the capstan.
- ! Take care not to allow “riding turns”. This is caused by the loaded line climbing on top of lower loaded coils. A riding turn can only be removed by paying out to the point where the riding turn is removed.

4.0 MAINTENANCE

4.1 EVERY TRIP

Ensure clutch is correctly engaged

The parts external of the case should be washed down with fresh water at the end of every trip.

! Failure to carry out the maintenance and service, as described herein, will invalidate warranty.

4.2 EVERY THREE MONTHS

Disassemble the above deck components of the windlass (up to the deckplate) as described in Section 2.3. Clean all components and check for damage. Grease the components using lithium complex base, water proof grease, especially grease the conical surface on both clutch cones, as shown on Picture 2.6. If deckplate has the grease nipple installed, grease bearing in the deckplate using the grease nipple.

Clean chromed surfaces with a cloth, damp with kerosene. After cleaning spray them with "CRC 3037 Long Life" or alternatively, with "CRC 6-66" or "WD-40". Regular use of "CRC3097 Long Life" will assist in maintaining the bright chrome finish.

Re-assemble in the reversed order.

Inspect the components below deck for corrosion, chipped paint etc, clean them, and touch up the paint if necessary. Spray them for protection with "CRC 3013 Soft Seal".

! Before doing any maintenance work on electric motor, starter units and wiring, make sure the power supply is switched off.

4.3 EVERY YEAR

Carry out the three monthly maintenance, as described above.

Remove gearbox/spacer tube.

Remove DC motor and service. Replacement brush sets are available:

Part No. P100808 – 24V

4.4 RECOMMENDED LUBRICANTS

Greases

- Lithium complex base NLG1 consistency No. 2

- CASTROL LMX
- DUCKHAMS Keenol
- FINA CERAN WR 2
- SHELL Retinex LX
- MOBIL Mobilgrease HP

Gearbox Oils

- ISO 3448 VG 320

- CASTROL Alpha MAX 320
- SHELL Tivela oil SC320
- MOBIL Mobilgear 632
- BP MACH GR XP 320

Anti-Corrosive Coatings

- CRC 3013 Soft Seal
- Boeshield T9
- Lanocote

Anti-Seize Coating

- International Paints Res-Q-Steel

Never mix greases, use only one type. If in doubt, remove the previous lubricant and clean the parts thoroughly before applying the new one.

4.5 SPARE PARTS

Maxwell recommends a modest quantity of spare parts to be ordered as familiarity with the windlass is developed during installation. Frequently smaller parts are lost during maintenance, so keeping spares (and spare tools) is recommended.

We recommend the following list of spare parts to be carried on board:

Part no.	Description	Qty
3227	Plastic Cap	1
5953	Disc Spring	2
2311	Retention Clip	2
3150	Key - Topworks	2
4635	Key - Gearbox	1
7068	Washer	1
2310	Spring	1
SP0878	Circlip	2

If you need any other spare part, please refer to the Appendix B for the correct part number and contact one of our distributors worldwide (Appendix E).

When ordering spare parts, please also quote the serial number of the windlass.

4.6 TOOLS FOR MAINTENANCE

We recommend the following tools be kept on board for disassembling and assembling the windlass:

- Set of metric hexagon keys
- Ring / open end spanner 13, 17, 19mm and 9/16"
- Flat screw driver 10mm blade width
- Circlip pliers

5.0 TROUBLESHOOTING

Problem	Possible Cause	Solution
The windlass does not move.	No electric power to controls.	Make sure the isolator switch for windlass controls is ON.
		Check the fuse on power supply to controls.
		Make sure the wiring is correct and check it for damage.
		If there is more than one type of control (pendant unit, footswitch, helm switch), check them all in an effort to isolate the problem.
	Check the power supply to controls from the source, step by step, and identify the point where it stops.	
	Incorrect or incomplete wiring.	Check wiring against diagrams supplied.
	No power supply to the windlass.	Check power supply lines.
		Check main isolator switch.
Windlass is not able to pull the specified load.	Motor voltage does not match the power supply on board.	Check name plate on the motor. If confirmed, contact Maxwell.
Motor draws high current but struggles to pull the load.	The mounting bolts of the motor are touching the motor winding.	Make sure the bolts have spring washers, adjust bolt length.
Windlass runs but the chainwheel stays stationary.	Windlass runs but the chainwheel stays stationary.	Tighten the clutch up, as described in Section 3.2. If the problem persists, contact Maxwell.
	Topworks key not installed.	Install the key.
Electric motor stops after prolonged heavy use.	The motor has been overloaded and has reached its critical temperature.	Leave it to cool down and reset the circuit breaker.
The anchor does not free fall.	The clutch cones are not greased.	Disassemble the clutch cones, clean and grease them as described in Section 2.4.
	The clutch is not fully disengaged.	Disengage the clutch fully.
	Disc springs not fitted.	Fit disc springs as described in Section 2.4.
	Pawl engaged.	Disengage pawl.
Chain jumps / slips on the chainwheel.	The chainwheel not selected correctly.	Contact Maxwell with correct identification of the chain used on board.
	Chain twisted between windlass and bow roller.	Untwist the chain.
	Vertical angle of incoming chain bigger than 2 degrees (Picture 2.2)	Check the installation. If the problem persists, some height adjustments might have to be made.

APPENDIX A - Dimensional Drawings

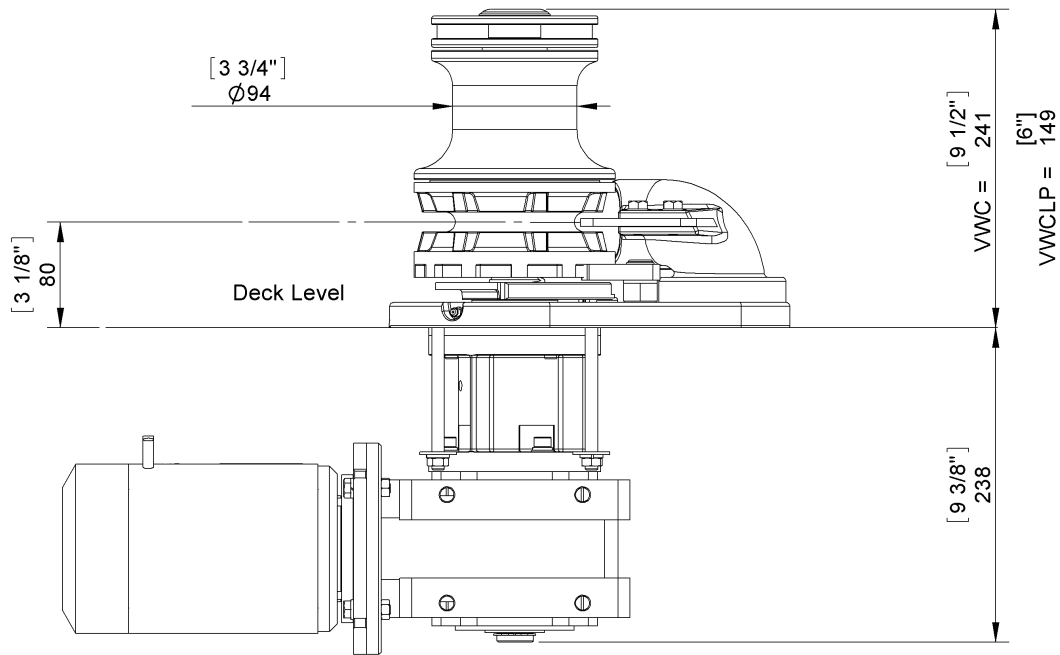
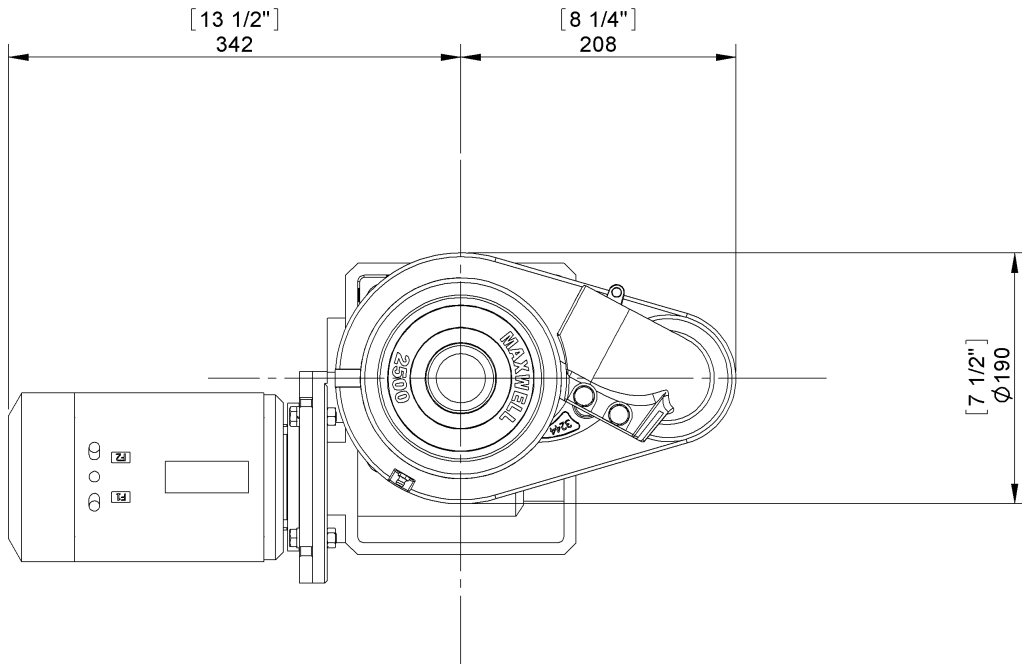

Sht Size	Scale	Dwg Type	Sheet	Description	Pbv/Dwg No.
A4	1:5	dftisd	1 of 1	2500 VWC VWCLP Overall dimensions	P100138

File location: \\apollo1\Engineering\Product Data\assemblies\P100000-P100999\P100138_5.00_dftisd_2500 VWC VWCLP overall dimensions for manu

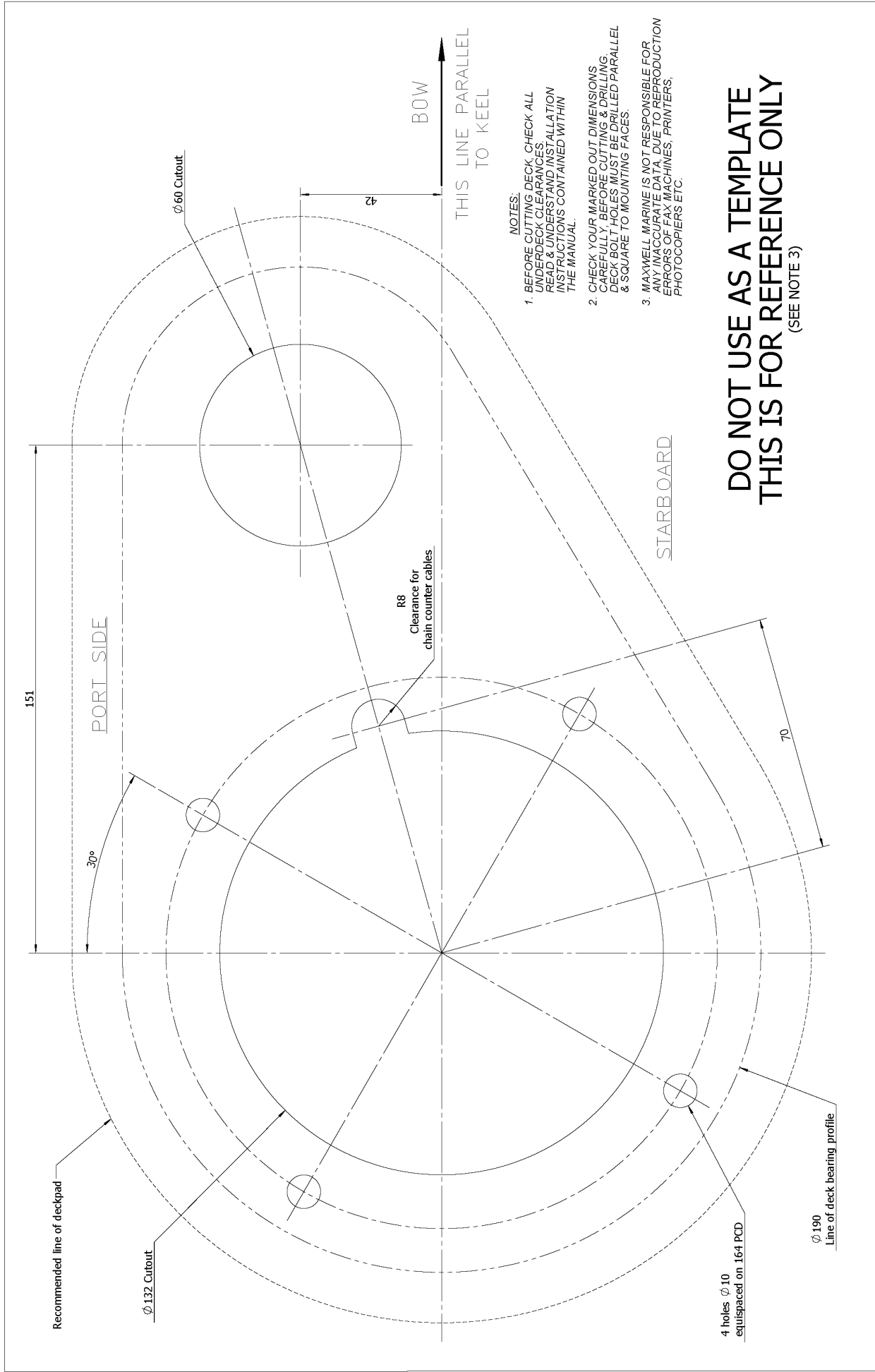

BOW
THIS LINE PARALLEL TO KEEL

NOTES:

1. BEFORE CUTTING DECK CHECK ALL UNDERDECK CLEARANCES. READ & UNDERSTAND INSTALLATION INSTRUCTIONS CONTAINED WITHIN THE MANUAL.
2. CHECK YOUR MARKED OUT DIMENSIONS CAREFULLY, BEFORE CUTTING & DRILLING. DECK BOLT HOLES MUST BE DRILLED PARALLEL & SQUARE TO MOUNTING FACES.
3. MAXWELL MARINE IS NOT RESPONSIBLE FOR ANY DAMAGE TO YOUR VESSEL OR TO THE PRODUCTION OF FAX MACHINES, PRINTERS, PHOTOCOPIERS ETC.

STARBOARD

**DO NOT USE AS A TEMPLATE
THIS IS FOR REFERENCE ONLY**
(SEE NOTE 3)

Revision	Change	Made on/By/Drawn	Description	Drawing No.	Revision No.
4.00	Dir. 50 was 58 - issued in CAD	8-03-02 DW	Deck Cutout Details - 2200 2500 VWC-VWCLP	3328	5.00
5.00	Template note added, Notes revised	29/9/06 RP			
<p>The drawing is protected by copyright and the design and or details contained therein are the confidential property of MAXWELL MARINE LTD. This drawing must be used upon receipt and must not be copied, altered or otherwise used in any way without the written consent of Maxwell Marine Ltd. This drawing must not be used for any other purpose other than that for which it was originally supplied.</p>			<p>Tolerances: if none specified 0 DECIMAL (X) ±0.5 1 DECIMAL (XX) ±0.2 2 DECIMAL (XXX) ±0.1</p>		
<p>Material: N/A</p>			<p>Sheet Size A3 Scale 1:1</p>		
			<p>ALL ANGLES ±0.5°</p>		
			<p>Sheet 1 of 1</p>		

APPENDIX B – Topworks Spare Parts

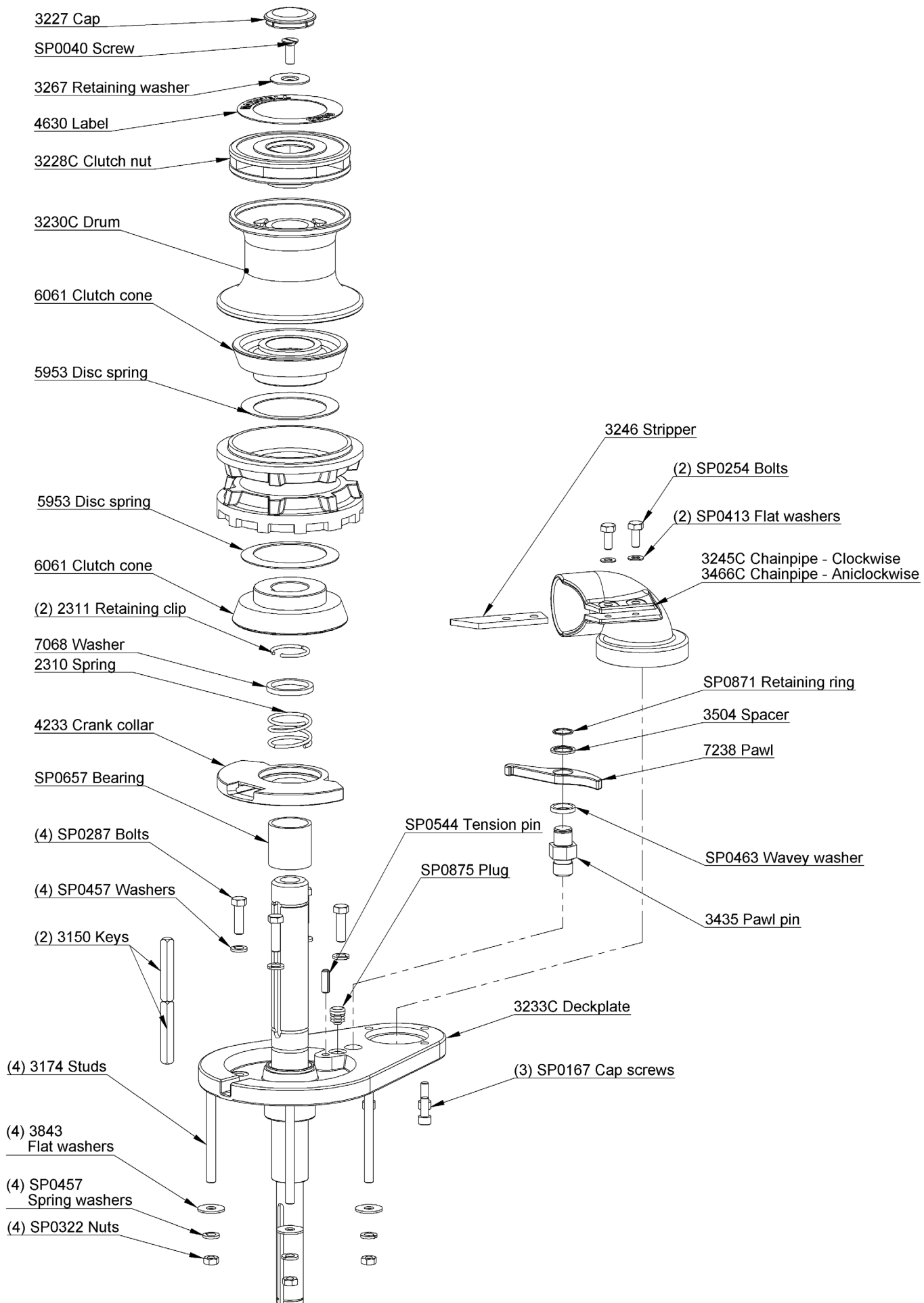

Bottomworks

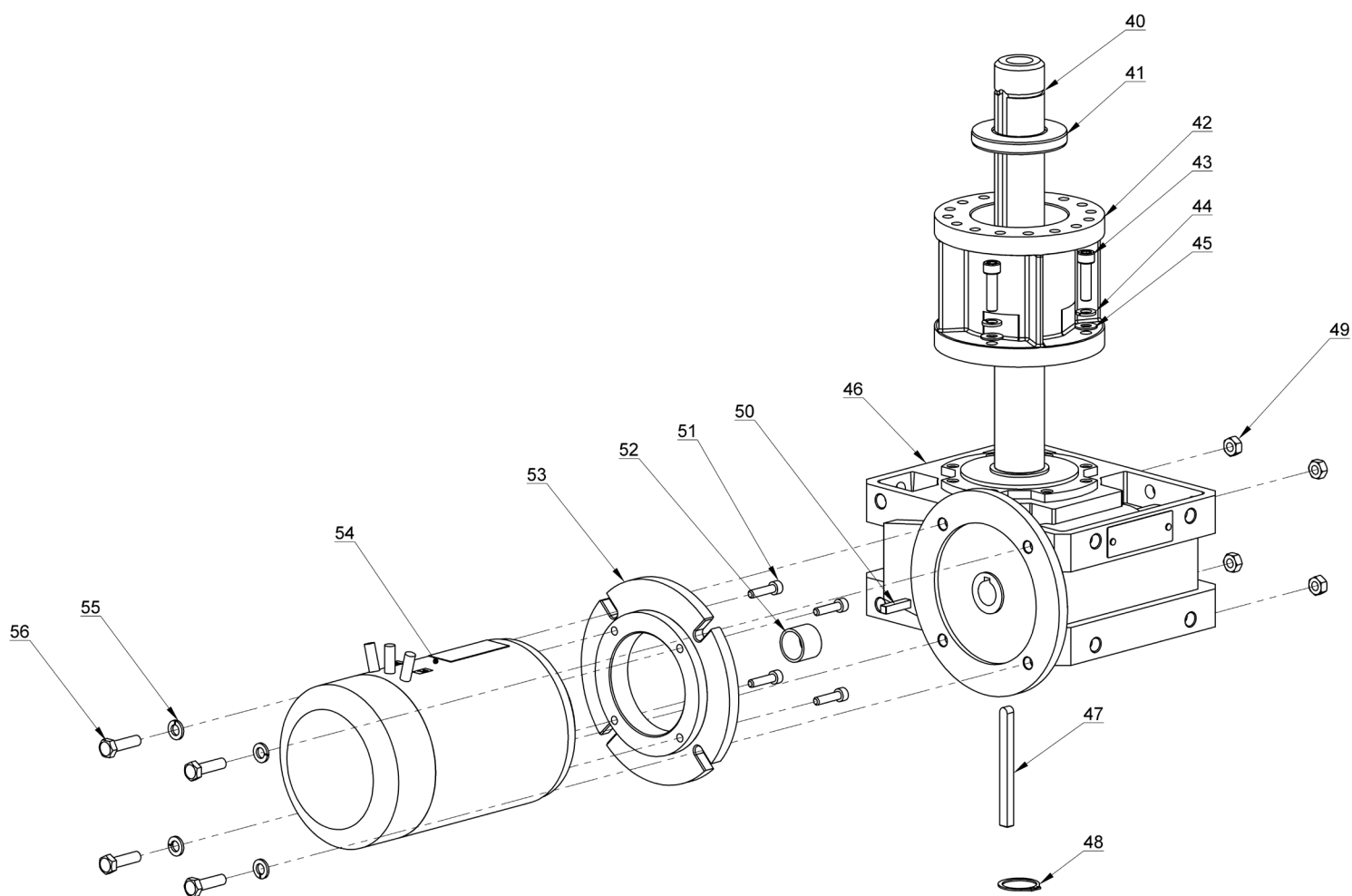

Item	Description	Qty	Part no.
40	Shaft VWC VWCLP	1 1	5498 5007
41	Oil Seal	1	SP2765
42	Spacer tube	1	5497
43	Socket head cap screw - M8 x 30	4	SP0171
44	Spring washer - M8	4	SP0467
45	Flat washer - M8	4	SP0428
46	Gearbox	1	P102089
47	Gearbox Key	1	4635
48	Circlip	1	SP0878
49	Hex Hd Nut M8	4	SP0366
50	Key	1	5116
51	Cap screw – M6 x 25	4	SP0175
52	Spacer	1	5487
53	Adapter plate	1	4592
54	24V Motor	1	SP2960
55	Spring washer - M8	4	SP0467
56	Motor Bolts - M8 x 30	4	SP0279
	Clutch nut handle	1	P20040
	User's Manual	1	P19163

APPENDIX C - Electrical Wiring Schematics

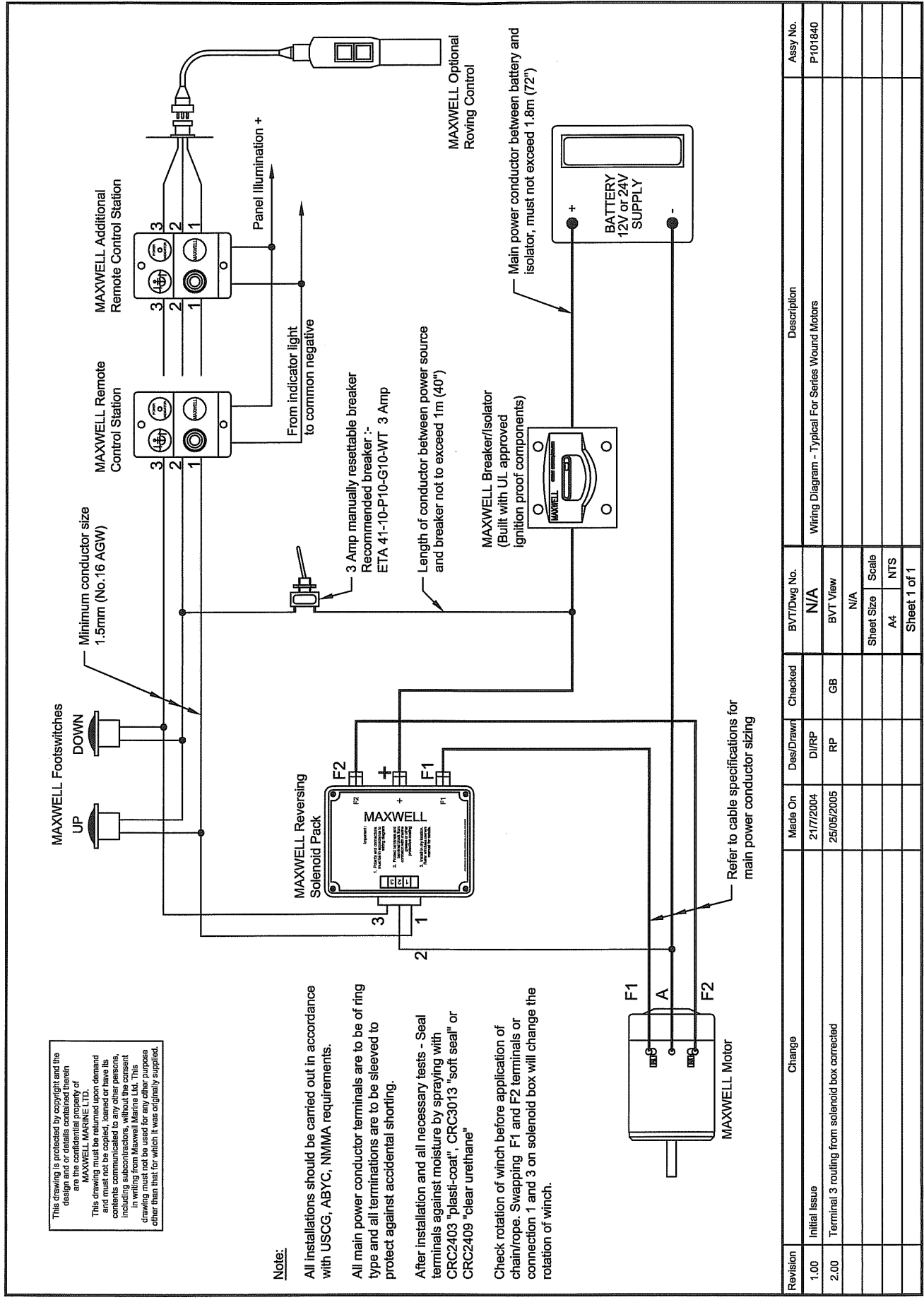

Revision	Change	Made On	Des/Drawn	Checked	BVT/Dwg No.	Description	Assy No.
1.00	Initial Issue	21/7/2004	DIRP		N/A	Wiring Diagram - Typical For Series Wound Motors	P101840
2.00	Terminal 3 routing from solenoid box corrected	25/05/2005	RP	GB	BVT View		
					N/A		
					Sheet Size	Scale	
					A4	NTS	
					Sheet 1 of 1		

LIMITED WARRANTY

Warranty: Maxwell Marine International Ltd provides a three year limited warranty on all windlasses for pleasure boat usage, and a one year limited warranty for those systems used on commercial or charter vessels. Warranty, service and parts are available around the world. Contact your nearest Maxwell office for a complete list of service centres and distributors.

This warranty is subject to the following conditions and limitations:

- This Warranty will be null and void if
 - there is any neglect or failure to properly maintain and service the products.
 - the products are serviced, repaired or maintained improperly or by unauthorised persons.
 - loss or damage is attributed to any act, matter or omission beyond the reasonable control of Maxwell or the purchaser.
- Maxwell's liability shall be limited to repair or replacement (as determined by Maxwell) of the goods or parts defective in materials or workmanship.
- Determination of the suitability of the product and the materials for the use contemplated by the buyer is the sole responsibility of the buyer, and Maxwell shall have no responsibility in connection with such suitability.
- Maxwell shall not be liable for any loss, damages, harm or claim attributed to:
 - use of the products in applications for which the products are not intended.
 - corrosion, wear and tear or improper installation.
 - improper use of the product.
- This Warranty applies to the original purchaser of the products only. The benefits of the Warranty are not transferable to subsequent purchasers.
- Maxwell shall not be responsible for shipping charges or installation labour associated with any warranty claims.
- There are no warranties of merchantability, fitness for purpose, or any other kind, express or implied, and none shall be implied by law. If any such warranties are nonetheless implied by law for the benefit of the customer they shall be limited to a period of three years from the original purchase by the user.
- Maxwell shall not be liable for consequential damages to any vessel, equipment, or other property or persons due to use or installation of Maxwell equipment.
- This Warranty sets out your specific legal rights allowed by Maxwell; these may be varied by the laws of different countries. In addition, the purchaser may also have other legal rights which vary from country to country.
- To make a claim under this Warranty, contact your nearest Maxwell Marine office or distributor. Proof of purchase and authorisation from Maxwell will be required prior to any repairs being attempted.



To be eligible for warranty protection, please either complete the form below at the time of purchase and return it to the appropriate retailer or supplier of the goods, or fill out the electronic warranty form on our website, www.maxwellmarine.com

Purchaser

Name:

Address:

Telephone:

Facsimile

Supplier / Dealer

Name:

Address:

Telephone:

Facsimile

Windlass Model

Serial Number

Date of Purchase

Boat Type

Windlasses Supplied

Name

L.O.A.

With boat

Fitted by boat yard/dealer

Purchased from dealer/chandler

Built by



NOTES: