

SHOCKWAVE

SHOCKWAVE S5
SENTINEL

SHOCKWAVE S5 **SENTINEL** | SUSPENSION MODULE

SW-07823-B | SW-07823-W



TRAVEL
4 IN

The SHOCKWAVE S5 Sentinel provides comfort and safety to boaters, offering them an experience they've never had before. It offers a smoother, safer and more comfortable ride, protecting occupants from the shock of wave impact. Recreational boaters can stay out longer and travel farther with less fatigue.

- ✓ Easy to install
- ✓ Can be paired with almost any seat
- ✓ Designed and manufactured in Canada

LEARN MORE ABOUT OUR PRODUCTS AT
SHOCKWAVESEATS.COM

+1-778-426-8545
sales@shockwavesseats.com

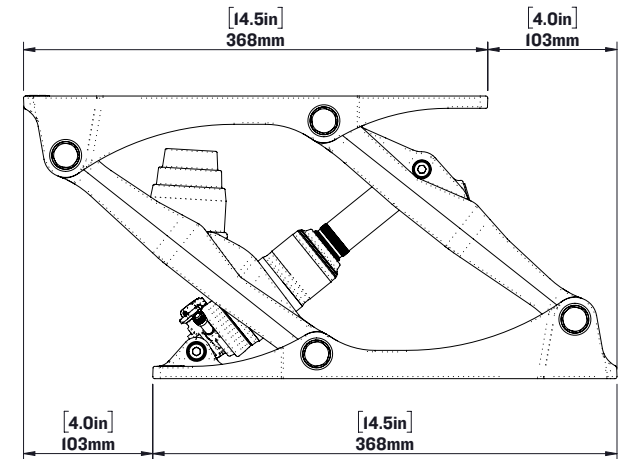
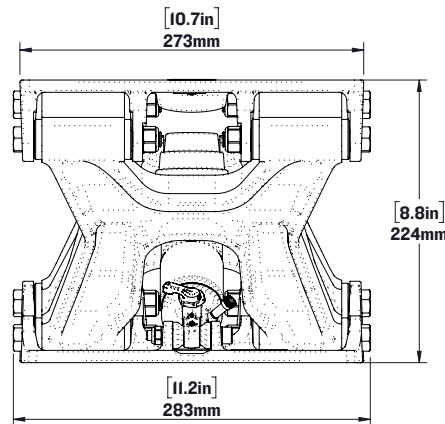
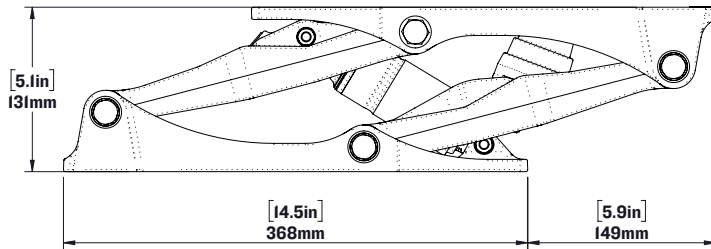
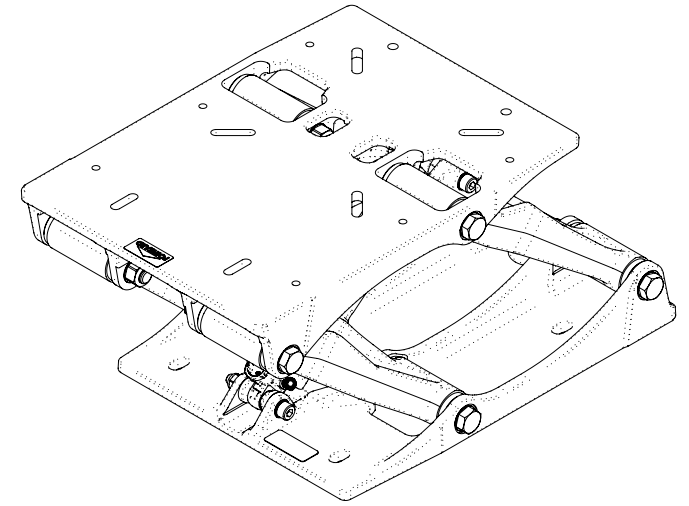
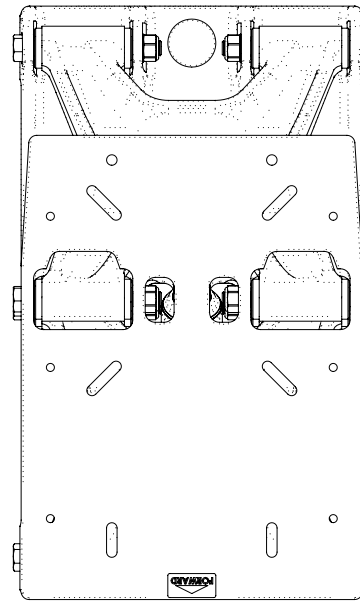
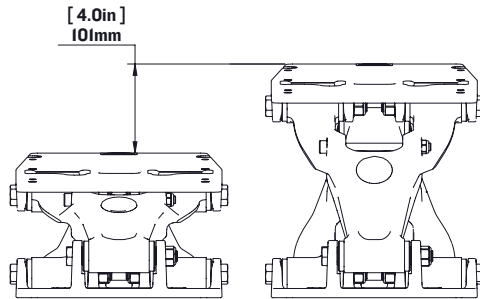

NOTE:
OCCUPIED SEAT HEIGHT WILL BE [1.0in] 25mm LOWER THAN LISTED DIMENSION

SHOCKWAVE

FOR MORE INFORMATION
CALL US AT 1-778-426-8545
OR VISIT US ONLINE AT
WWW.SHOCKWAVESEATS.COM

PROPRIETARY AND CONFIDENTIAL

NOTICE: THIS DRAWING MAY REVEAL DESIGNS OR INFORMATION PROPRIETARY TO PROFESSIONAL COMPONENTS LTD. BY ACCEPTANCE OF REPRODUCTIONS, RECIPIENTS AGREE TO PROTECT PROFESSIONAL COMPONENTS LTD. RIGHTS AND ARE WARNED AGAINST USE OF THE DOCUMENT FOR ANY PURPOSE OTHER THAN THAT FOR WHICH IT WAS ISSUED.

SW-07823
S5 Sentinel Module

WEIGHT: [27.5 lbs] 12.5 kg

SCALE: 1:24

SHEET 1 OF 1

REV: 00